

SCALE 3:20

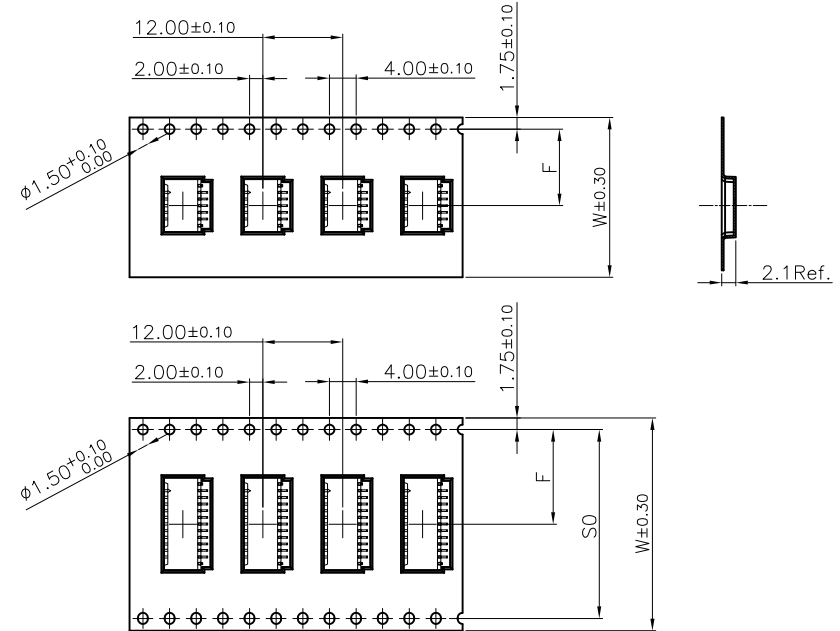

1. 包裝方式:

- 1.1. 使用半自動包裝,先將CARRY TAPE送入導軌中,並將COVER TAPE貼合在上面;其中初始200mm(約16pcs)空槽不要放產品,然後將產品如圖所示方向依次放入CARRY TAPE內,每個槽放1PCS,每REEL共包裝產品2500PCS,最後需留200mm(約16pcs)空槽不放產品;
- 1.2. 用膠帶將CARRY TAPE綁在一起,外圍再用塑膠帶纏繞一圈,在REEL上貼上各個標籤;之後放入氣泡袋,並將口封好。
- 1.3. 如圖示,將aPCS已裝好成品的REEL放入PE袋中,PE袋內放1PCS的干燥劑,紙箱中先放1PC紙板,再將裝好產品的PE袋放入,再放1PCS紙板,四周放入折疊板;膠帶封箱,並在注明相關內容。

注意:

1. 防止漏裝,禁止碰歪產品錫腳;
2. 產品在CARRY TPAE中的方向須如圖所示;
3. COVER與CARRY剝離力:30.0--100gf,速度:300mm/min.;
4. 确认包裝标识/标签满足客户和厂内管制要求;
5. 确认HSF标签满足管制要求;

3. 包裝數量描述:

PIN NO.	DIM W	DIM F	DIM So
004~005	16.0	7.50±0.10	--
006~012	24.0	11.50±0.10	--
013~015	32.0	14.20±0.10	28.4



DATE	OLD REV	NEW REV	ECN	DESCRIPTION	CHECK	APPROVAL
1						
2						
3						
4						

GENERAL TOLERANCE	
.X	±0.30
.XX	±0.20
.XXX	±0.10

**昆旺精密连接器有限公司**  
VIGORCONN PRECISION CONNECTOR CO., LTD

APPROVAL	CHECK	DRAWN	DATA
Kim Huang	Jova Lau	Yu wei	2008/04/24

PART NO. F1022 XX - H x x x 8			
TITLE. 1.0P 1.5H FPC NON-ZIF CHKD: R/A SMT TYPE.-CUST DWG			
UNIT MM	SCALE 1:1	NUMBER A-000	REV A

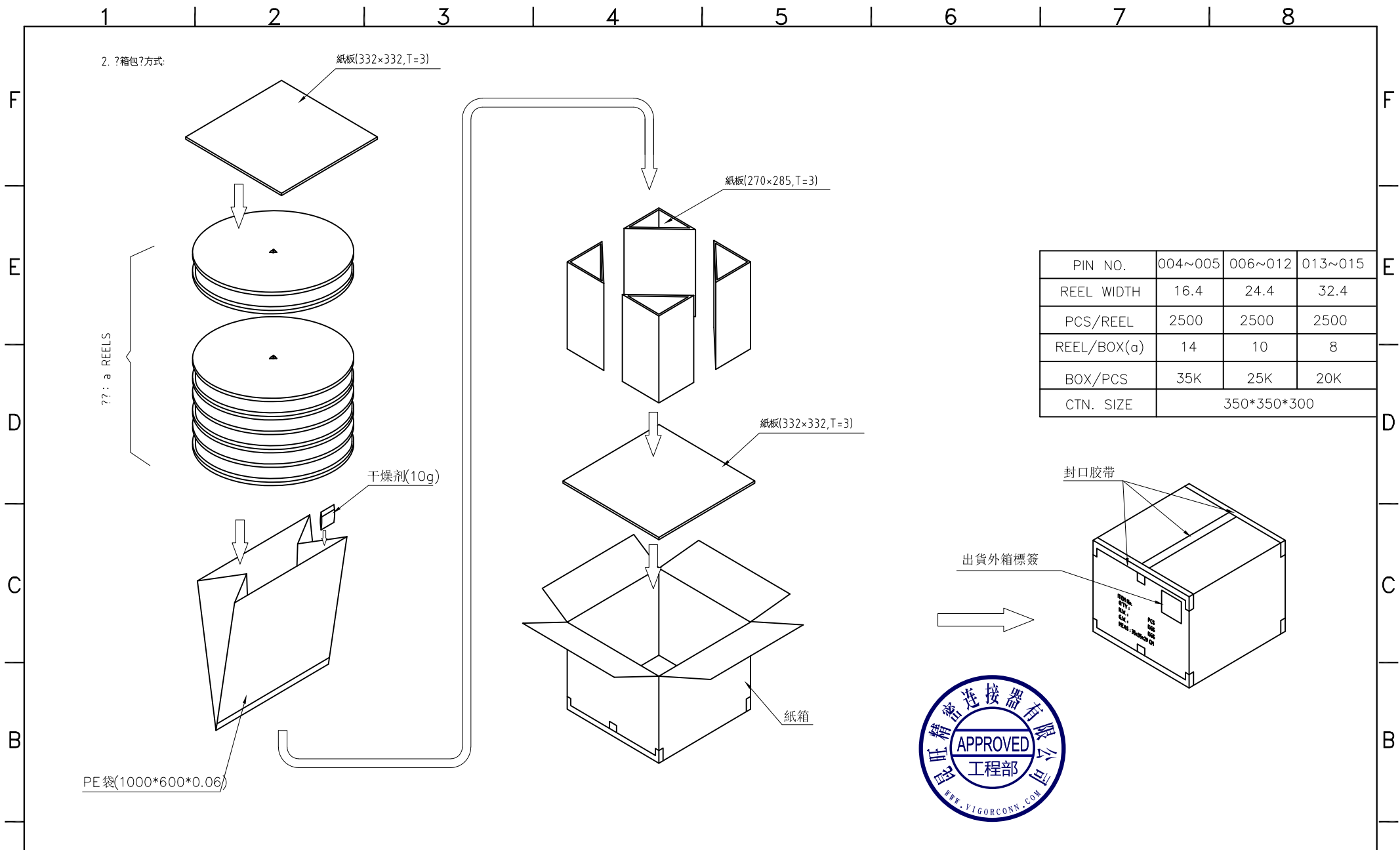

PIN NO.	004~005	006~012	013~015
REEL WIDTH	16.4	24.4	32.4
PCS/REEL	2500	2500	2500
REEL/BOX(a)	14	10	8
BOX/PCS	35K	25K	20K
CTN. SIZE	350*350*300		



								<b>GENERAL TOLERANCE</b> .X ±0.30 .XX ±0.20 .XXX ±0.10		<b>昆旺精密连接器有限公司</b> VIGORCONN PRECISION CONNECTOR CO., LTD				<b>PART NO.</b> F1022 XX - H x x x 8							
								<b>PROJECT</b> 		<b>APPROVAL</b> Kim Huang		<b>CHECK</b> Jova Lau		<b>DRAWN</b> Yu wei		<b>DATA</b> 2008/04/24		<b>TITLE.</b> 1.0P 1.5H FPC NON-ZIF CHKD: R/A SMT TYPE.-CUST DWG			
<b>DATE</b>	<b>OLD REV</b>	<b>NEW REV</b>	<b>ECN</b>	<b>DESCRIPTION</b>	<b>CHECK</b>	<b>APPROVAL</b>				<b>UNIT</b> MM	<b>SCALE</b> 1:1	<b>NUMBER</b> A-000	<b>REV</b> A								