

1 2 3 4 5 6 7 8

F
E
D
C
B
A

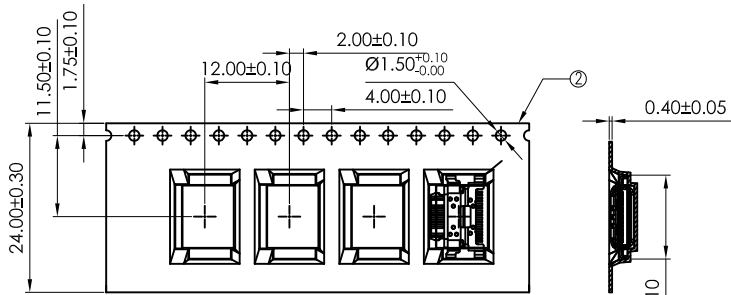

Notes:

1.Quantity/Reel:1500pcs/Reel
数量/卷:1500pcs/卷
Quantity/OuterCarton:1500 *10=15000 pcs
数量/外箱:1500 *10=15000 pcs

2.Weight:

N.W:7.2Kg G.W:11.9±0.5Kg
净重:7.2Kg 毛重:11.9±0.5Kg

3.Free 22 pcs Products In the Front Carrier And
Free 22 pcs Products In the End Carrier.
载带前后各空22格。

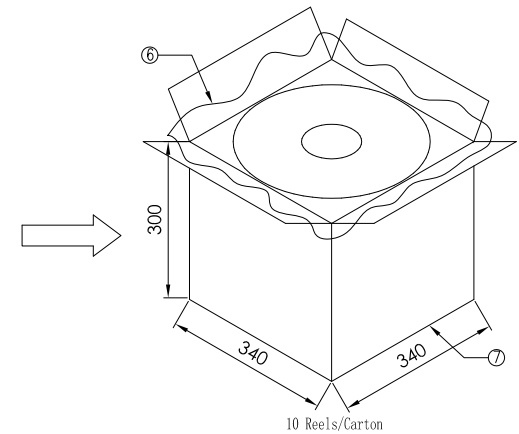
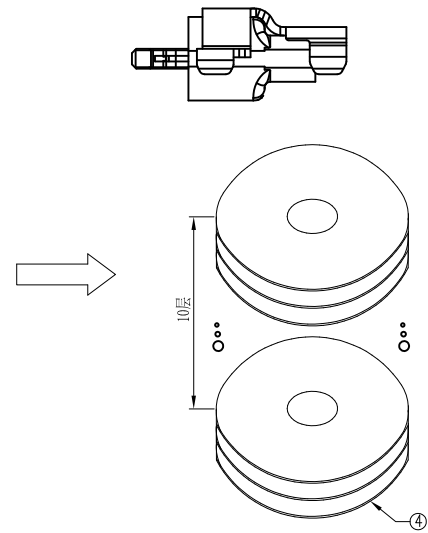
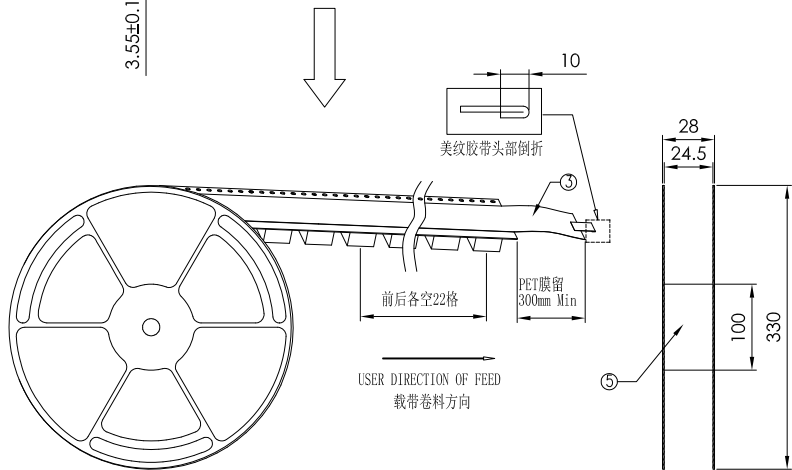
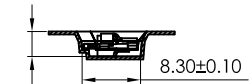

⑦	Outer Carton	1	K=K	34*34*30cm ³	90001
⑥	PE Beg	1	PE	(400+250)x800x0.06mm	92003
⑤	Paperboard Axle	10	Paper	Color:White	P-0124-091
④	Paperboard Tray	20	Paper	t=1.75mm,Color:White	
③	Cover Tape	20.602m	PET	t=0.06mm,W=21.3mm	96001
②	Carrier Tape	18.528m	Transparent PS	t=0.40mm	P-0001-078
①	Product	1500		1.5K/Reel 15K/Carton	KWUB31A-16C2-LV3TA-104205
NO.	PART NAME	Q'TY	MATERIAL	REMARKS	PART NO.



DATE	OLD REV	NEW REV	ECN	DESCRIPTION	CHECK	APPROVAL	PROJECT		

GENERAL TOLERANCE
X. ±0.38
.X ±0.25
.XX ±0.10
.XXX ±0.05

昆旺精密连接器有限公司
VIGORCONN PRECISION CONNECTOR CO., LTD

PART NO. KWUB31A-16C2-LV3TA-104205			
TITLE. TYPE C REC CH= -0.1 MID MOUNT TYPE (外露2.0)			
UNIT MM	SCALE 1:1	NUMBER A-00	REV A

APPROVAL	CHECK	DRAWN	DATA
Kim Huang	Jova Lau	Xiao Wen Xuan	2019/05/15

1 2 3 4 5 6 7 8